

THE PROPERTY OF THE DRAWING IS ESTABLISHED BY LAW. IT IS FORBIDDEN TO PRODUCE OR SHOW IT TO THIRD PARTY, WITHOUT A WRITTEN AGREEMENT.

Item	Name	Q.ty
1	CA.GWP.5.15	1
2	CA.SCM.10	1
3	R.05.15	1
4	R.5.SCH	2
5	V.TCE5x12	2

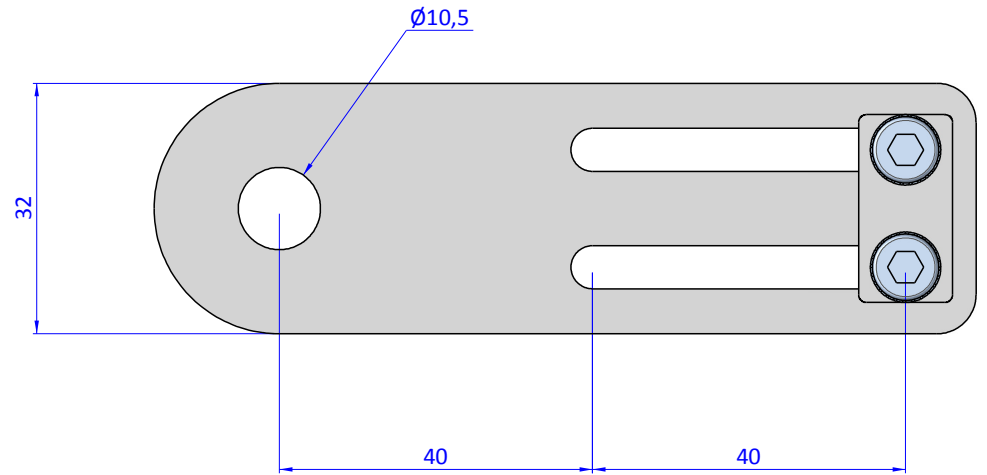
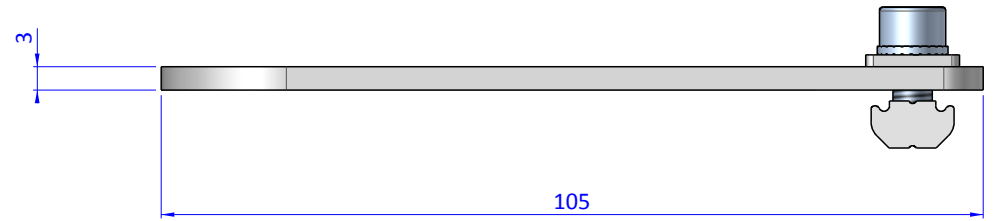
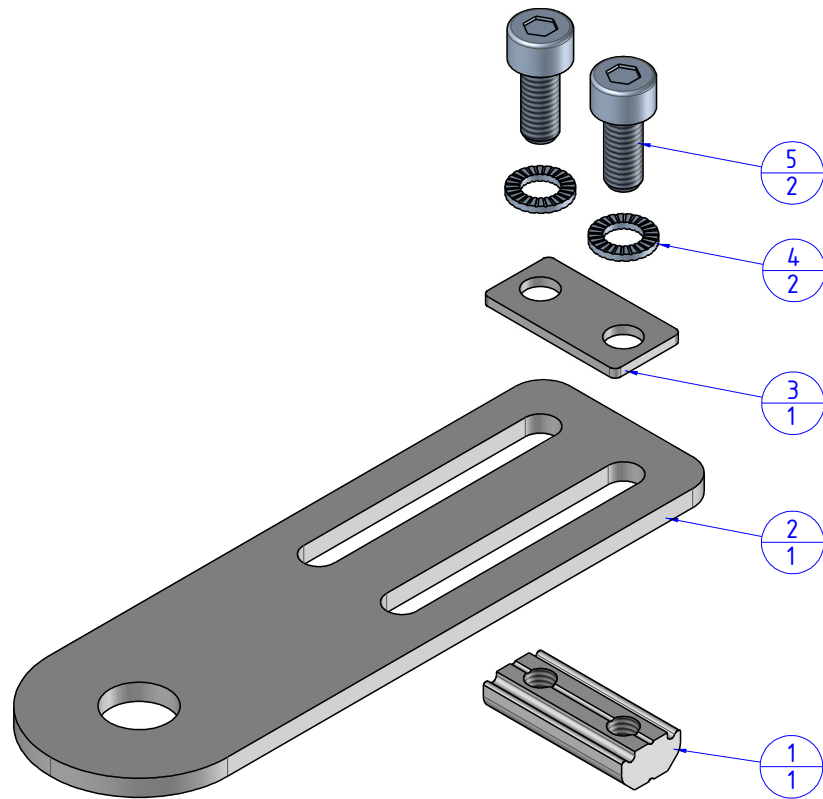

Format A3

UNI 936-76

		DESIGNED FROM		REVIEW
		FPSERVICES		A
GENERAL TOLERANCE		DATE	WEIGHT	
UNI - ISO 2768		16/04/2018	0,084kg	
CLASSE f		CODE		
		CA.SCM.10.X		